

# HJBM PLUS 30 T4 0,12kW (268313106)

## GENERAL DATA



SQUARE WALL PLATE FAN, VARIABLE PITCH BLADES AND HIGH EFFICIENCY MOTOR

### MANUFACTURING FEATURES

- Squared frame in galvanized steel sheet with C4 anti-corrosion finish.
- Variable pitch angle polyamide impeller reinforced with fibreglass.
- Supplied with motor support and protection guard according to the UNE-EN 20-359-74 norm and the ROHS 2002/95/EC Directive (Restriction of the Use of Certain Hazardous Substances in Electrical and Electronic Equipments).
- High efficiency standard asynchronous squirrel-cage motor with IP-55 or IP-54 protection (wiring box IP-65) and Class F insulation. Manufactured with standard voltages: 230V 50Hz for single phase motors, 230/400V 50Hz for three phase motors.

### APPLICATIONS

Designed for wall assembly, they are suitable for:

- Air renewal in buildings and industries.
- Maximum working temperature: single phase 50°C, three phase 60°C.

### UNDER REQUEST

- Aluminium impeller.
- 60Hz fans.

## PERFORMANCE CURVE

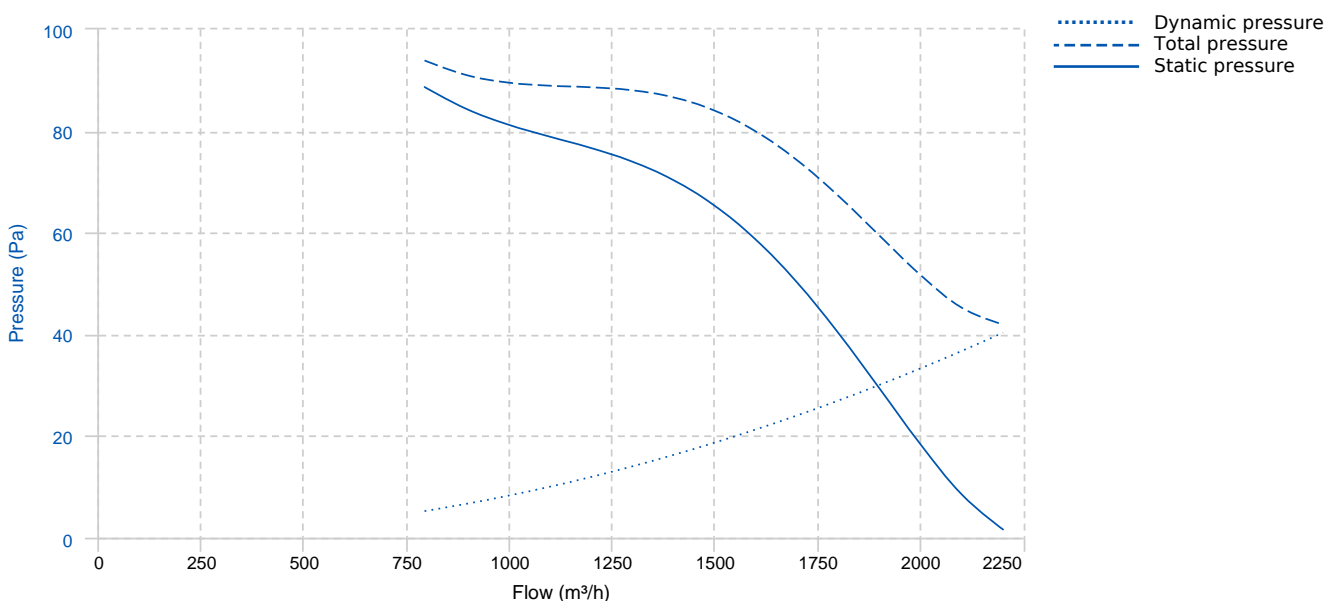

## TECHNICAL DATA

Fan							
RPM	1400	Approx. weight	5 kg	Max. Flow	2210 m³/h		
Motor							
Power	0,12 kW	RPM	1400	I max. (230V)	0,8 A	I max. (400V)	0,46 A
Size	63	Approx. weight	4 kg				

## DIMENSIONS

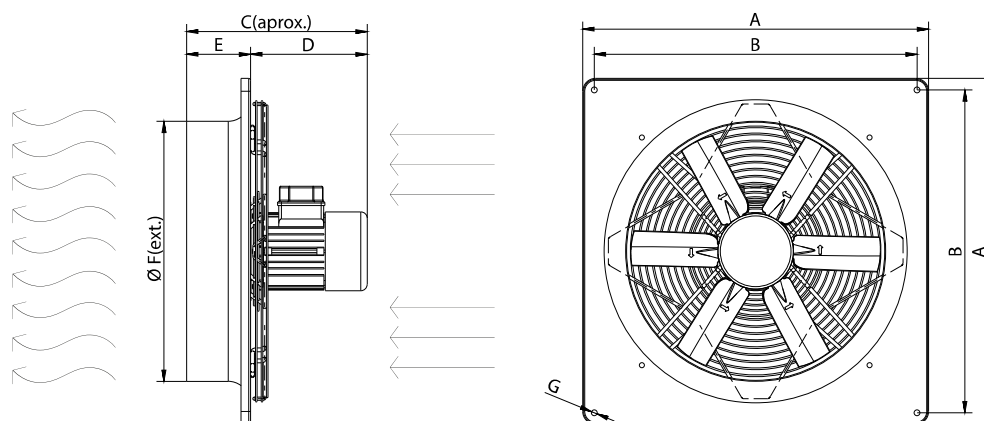

### Dimensions (mm)

A	404	B	337	C	274,5	D	192,8	E	82
ØF	308	ØG	9						

## WIRING DIAGRAM

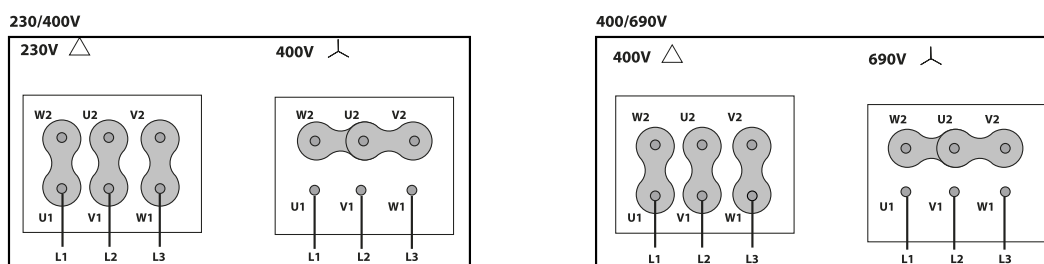

## ACCESSORIES



**SAFETY SWITCH**  
**INT 25 3P A**  
**REF: INT253PA**



**Outlet protection guard for axial fans**  
**RPO 30**  
**REF: 980000030**



**PLASTIC GRAVITY SHUTTER**  
**PCP 30**  
**REF: 963220105G**



**ALUMINIUM GRAVITY SHUTTER**  
**PC2 30**  
**REF: PC23030**



**FREQUENCY SPEED CONTROLLER**  
**SFC 230 I 2,5A \***  
**REF: SFC230I003**



**FREQUENCY SPEED CONTROLLER**  
**SFC 400 III 1,2A \***  
**REF: SFC400III1**

## SPARE PARTS

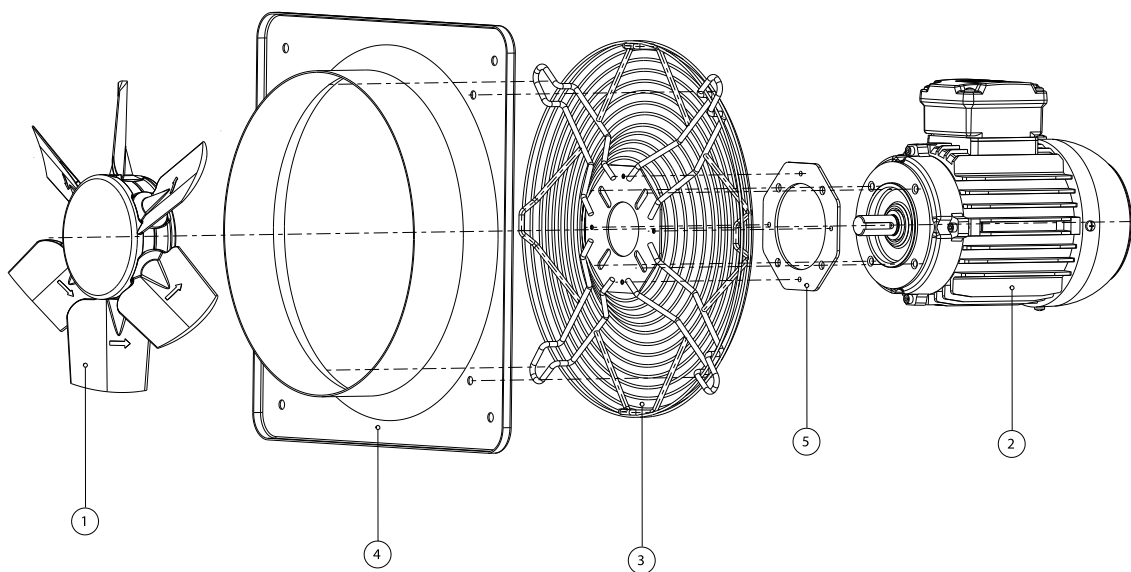

	Code	Model	Qty
1	R-H30006140PSTD	IMPELLER 300:AP0:6 G40 D11	x1
2	721001114IE2	MOTOR 0,12KW.1500 B14 230/400V.	x1
3	R-268301902	PROTECTION GRID HJBM30	x1
4	R-265311778A001	FRAME HJEM-HJBM30	x1
5	R-268401909	SUPPORT MOTOR DISC HJBM25-30-35-40 T.63	x1